



UNITED MOTORS SERVICE
 DIVISION OF
GENERAL MOTORS CORPORATION
 GENERAL OFFICES—DETROIT
AUTO RADIO BULLETIN

BULLETIN	6 D-828
Chevrolet	985426
Date:	8-29-47
Page	1
Supersedes Issue Of	
12-1-41	

SUBJECT--SERVICE INSTRUCTIONS
 Chevrolet Model 985426 Auto Radio

GENERAL

Mounting - Custom 1939 Chevrolet
 Type - Single Unit Set
 Tubes - Six
 Speaker - 6" Dynamic
 Tone Control - Mounted on Control Head
 Intermediate Freq. - 260 Kc
 Tubing Range - 540/1560 Kc

ALIGNMENT PROCEDURE

To properly align this receiver, a calibrated Test Oscillator or Signal Generator and Output Meter or Output Indicator are required. All adjustments should be made with the Volume Control set for maximum volume, keeping the Signal Generator output at minimum for satisfactory output indication. Tone Control to be in treble position.

Series Cond. or Dummy Antenna	Connection at Radio	Set Generator At	Tune Receiver To	Adjust Screws At	To Obtain
.1 Mfd.	6A8 Grid	260 Kc	No Broadcast Signal	A 2nd IF B trimmers	Max.
				C 1st IF D trimmers	
.0002 Mfd.	Antenna	1560 Kc	gang out of mesh	Osc E trimmer	Output
		1400 Kc	Signal Generator	Ant & RF trimmers	
		600 Kc	Signal Generator	Osc F padder	

Adjust trimmer F to match car antenna (600 Kc) when set is installed.

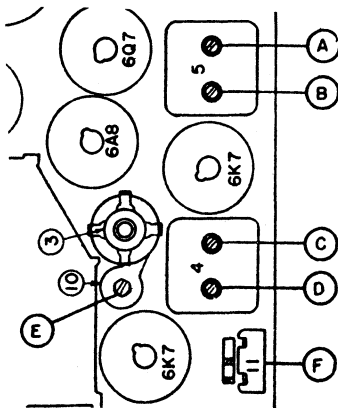

IF, Osc trimmers

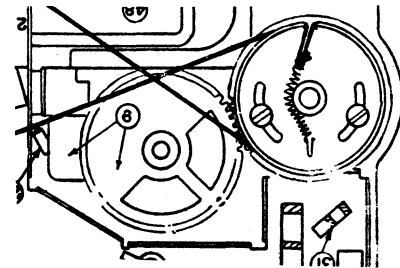

Ant & RF trimmers
 top and bottom of
 gang condenser

Contributed by Gene Thompson

SUBJECT--SERVICE INSTRUCTIONS - Cont'd.

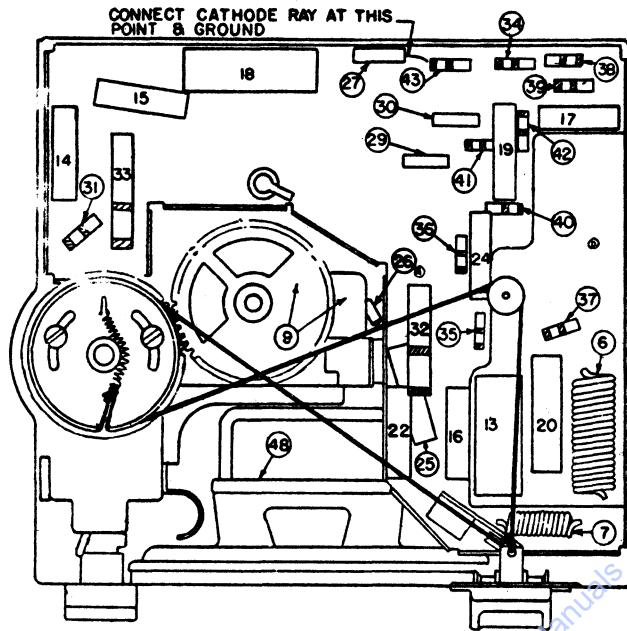

FIG. 2--PARTS LAYOUT--Bottom View

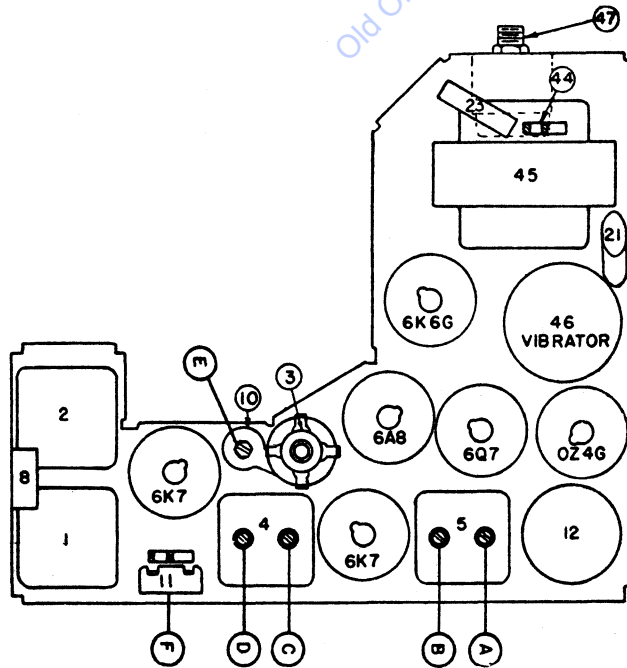

FIG. 3--PARTS LAYOUT--Top View



UNITED MOTORS SERVICE
 DIVISION OF
GENERAL MOTORS CORPORATION
 GENERAL OFFICES—DETROIT
AUTO RADIO BULLETIN

BULLETIN 6 D-828
 Chevrolet 985426
 Date: 8-29-47
 Page 3

SUBJECT--SERVICE INSTRUCTIONS - Cont'd.

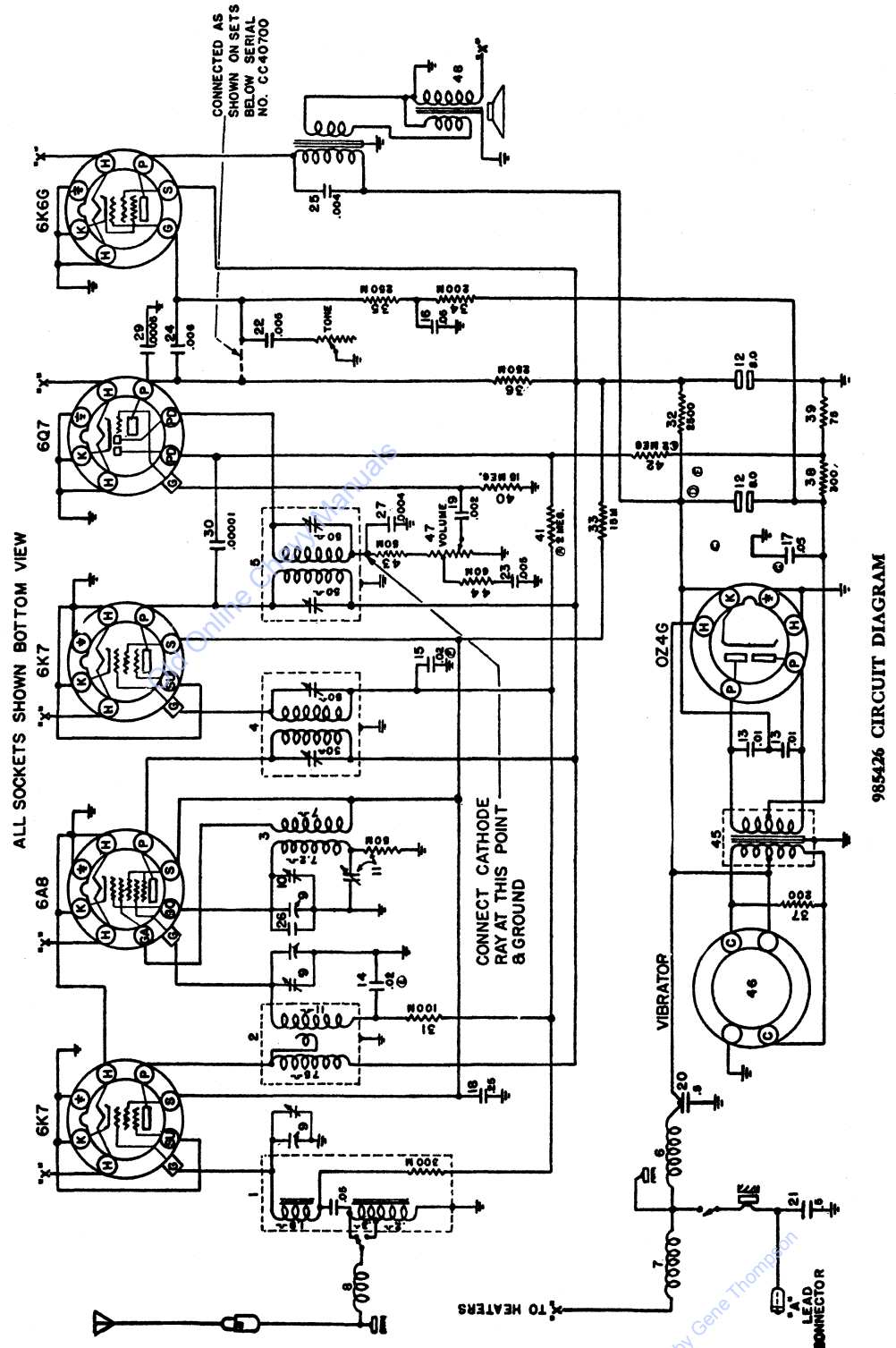

FIG. 1--CHEVROLET MODEL--985426 CIRCUIT DIAGRAM

SUBJECT--SERVICE INSTRUCTIONS - Cont'd.

SERVICE PARTS LIST

<u>Illus No.</u>	<u>Service Part No.</u>	<u>Description</u>	<u>Illus No.</u>	<u>Service Part No.</u>	<u>Description</u>
CONDENSERS			RESISTORS		
12		12-12 Mfd electrolytic	31	A104	100,000 Ohm $\frac{1}{2}$ watt Ins
13	H901	.01-.01 Mfd tub buffer	32	C222	2500 Ohm 2 watt Ins
14,15	E203	.02 Mfd tub	33	C152	15000 Ohm 2 watt Ins
16,17	E503	.05 Mfd tub	34	A184	200,000 Ohm $\frac{1}{2}$ watt Ins
18	E254	.25 Mfd tub	35,36	A224	250,000 Ohm $\frac{1}{2}$ watt Ins
19	E202	.002 Mfd tub	37	A181	200 Ohm $\frac{1}{2}$ watt Ins
20	E504	.5 Mfd tub	38	A271	300 Ohm $\frac{1}{2}$ watt Ins
21		.5 Mfd flat	39		75 Ohm $\frac{1}{2}$ watt Ins
22,23	E502	.005 Mfd tub	40	A156	15 Megohm $\frac{1}{2}$ watt Ins
24	E602	.006 Mfd tub	41,42	A185	2 Megohm $\frac{1}{2}$ watt Ins
25	E402	.004 Mfd tub	43	A473	50,000 Ohm $\frac{1}{2}$ watt Ins
26		temp. comp.	44	A563	60,000 Ohm $\frac{1}{2}$ watt Ins
27	G391	.0004 Mfd molded			
29	G471	.0005 Mfd molded	46	8526	Vibrator
30	G100	.00001 Mfd molded			